

Wood Pellets Burner

Bio comfort

100 step modulated
Woody Generation



EN 303-5 approved by DTI (Danish Technological Institute)
Approved for pressure expansion
Energy class AA

Manual

NBE pellet system

INSTALLATION GUIDE FOR COMFORT BOILER

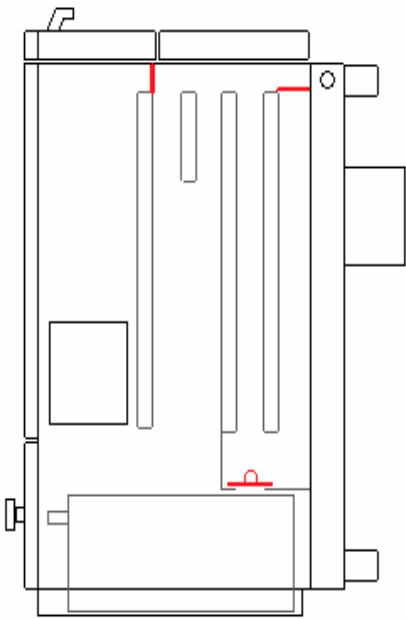
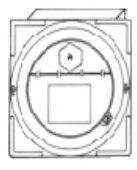
		Comfort	Opop	 <p>Dragex Draught stabilizer</p>
	Height	1050mm	850mm	
	Width	700mm	380mm	
	Depth	700mm	560mm	
	Chimney	130mm	130mm	
	Forward flow	1 1/4"	1 1/4"	
	Back flow	1 1/4"	1 1/4"	
	Lining	1/2"	1/2"	
Efficiency	93,3%	89,7%		

General guidelines:
 The boiler should be installed by an authorized fitter and must be installed in accordance with work supervision publication 42 (Danish) covering equipment working with water.
 The outlet duct should be no longer than 1m, and should be fitted with a cleaning door.
 The chimney draught should be at least 5 PA and should be stable, a draught stabilizer should always be installed.
 If combustion gases condense in the chimney (wet ash) install a draught stabilizer in the chimney, or open the flue (the flap inside at the back of the boiler) as wide as possible to increase the temperature of the smoke.
 The boiler must be spanned with a bypass to ensure the back flow is always kept above 55 degrees.

Installing the combustion chamber into the Comfort boiler:

1. Install the combustion chamber on the side of the boiler (there should be no shield on the combustion chamber).
2. Fit the controls either into a cabinet or on the wall.
3. Install the overheating safety fuse into the pocket on the side of the boiler, and connect the controls so that the overheating safety fuse will cut the power if the boiler overheats.
4. Install the heat sensor on the forward flow, either in the pocket or by the sensor on the forward flow. (The sensor must be insulated to the forward flow.)
5. Fit the pipe on the drop shaft (this must be the pipe that comes with the Comfort boiler).
6. Fit the hopper and auger so that the pipe slopes.
(PELLETS MUST NOT GET STUCK IN THE PIPE.)
7. You can run water into the equipment and the pellets will be washed down the auger in accordance with the manual for the wooden pellets burner.

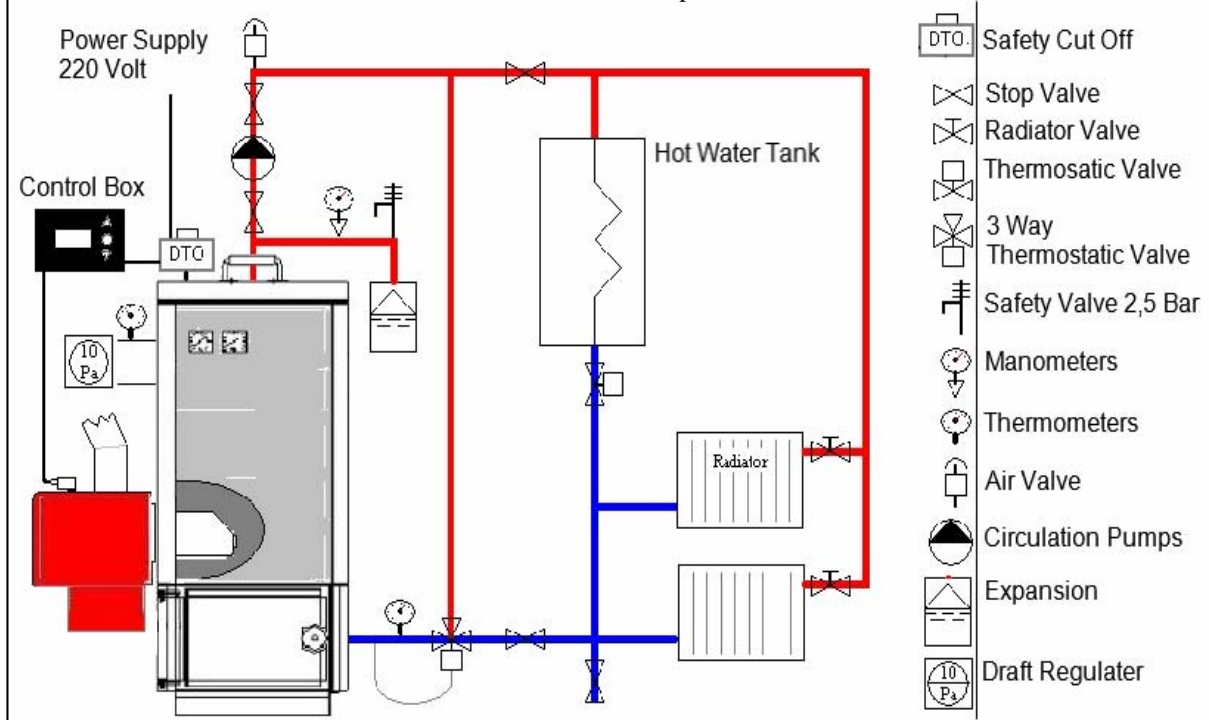

Diag. Example of installation

Manual

NBE pellet system

BOILER INSTALLATION GUIDE

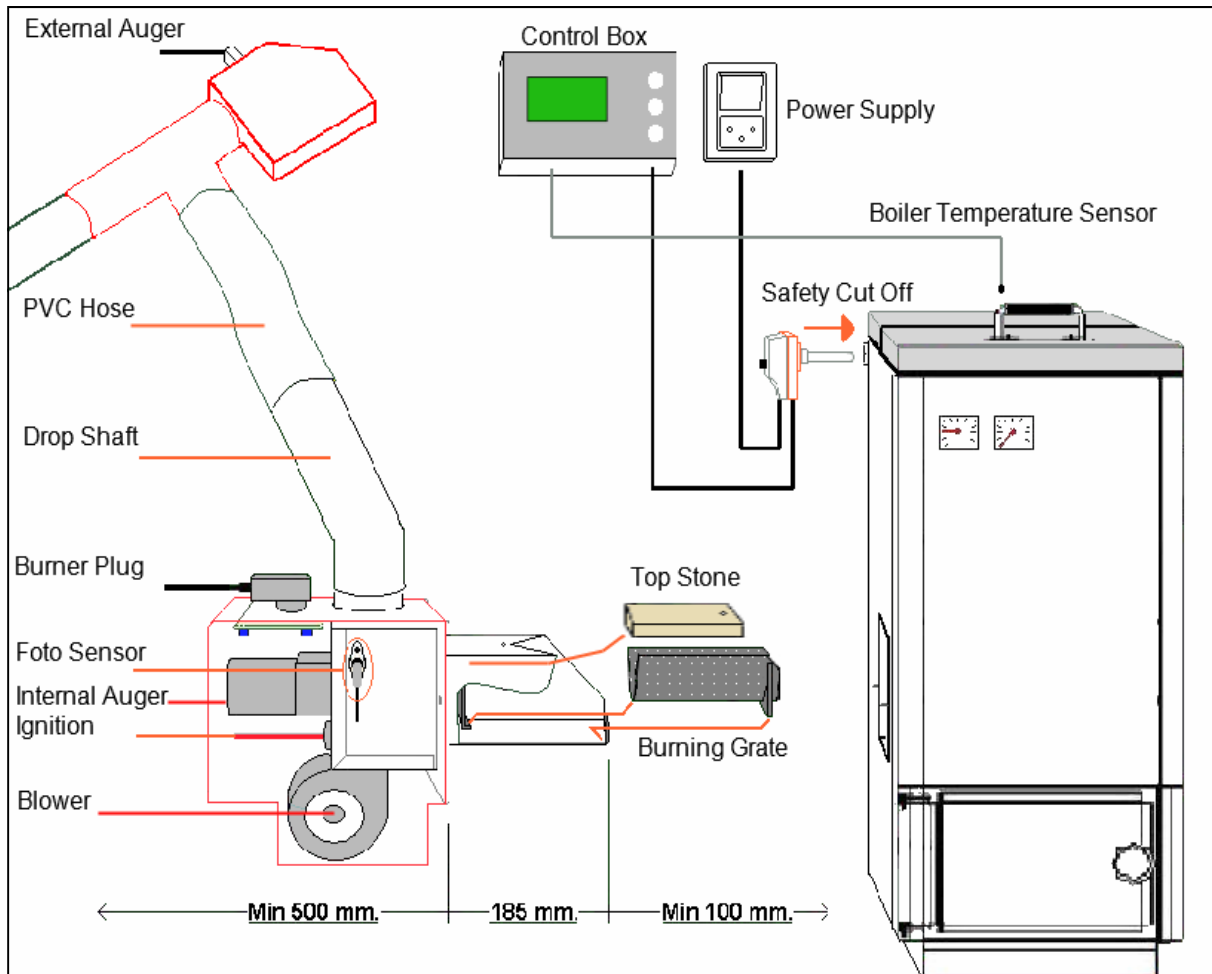

Installing into boiler:

1. Check that the combustion chamber is undamaged.
2. Fit the combustion chamber and tighten it firmly using the two wing nuts supplied.
3. Ensure that the combustion chamber is in a horizontal position and all connections are tight.
4. Fit the cover and the plug.
5. Wire up the overheating safety fuse following the electrical wiring diagram.

Outer auger:

6. Install the auger through the opening over the combustion chamber.
7. Ensure that the pipe slopes enough to allow the pellets to fall into the combustion chamber.

When using for the first time:

8. Make sure there are enough pellets by the entrance to the outer auger.
9. Force-start the auger by holding down the UP button by the power input point.
10. If the pellets fall into the combustion chamber, turn off again by pressing DOWN. Then restart the burner using electrical ignition.

Turning off the alarm:

11. If the alarm goes off or the burner will not start, switch the burner off and on again using the ON/OFF switch on the regulator.

Manual

NBE pellet system
SETTING BY WEIGHT

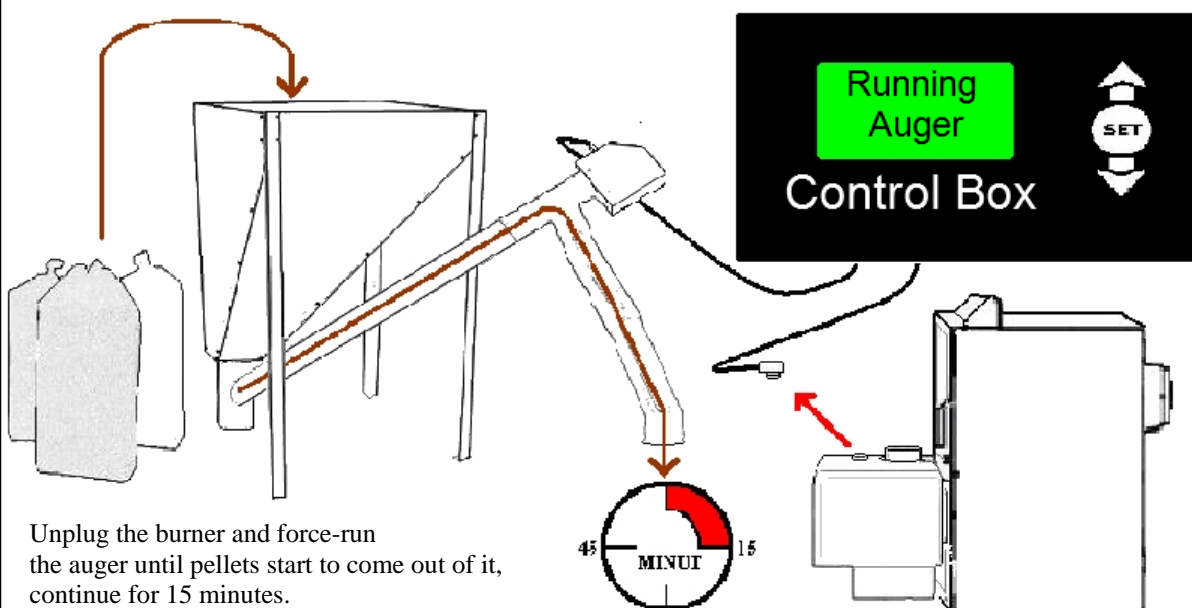

Unplug the burner and force-run the auger until pellets start to come out of it, continue for 15 minutes.

Running Auger
Control Box

45 MINUT 15

Diagram description: A schematic of a pellet system with a hopper, auger, and burner. A control box is shown with a green 'Running Auger' button and a 'SET' button with up/down arrows. A timer on the control box is set to 15 minutes. A red arrow points from the control box to the burner area.

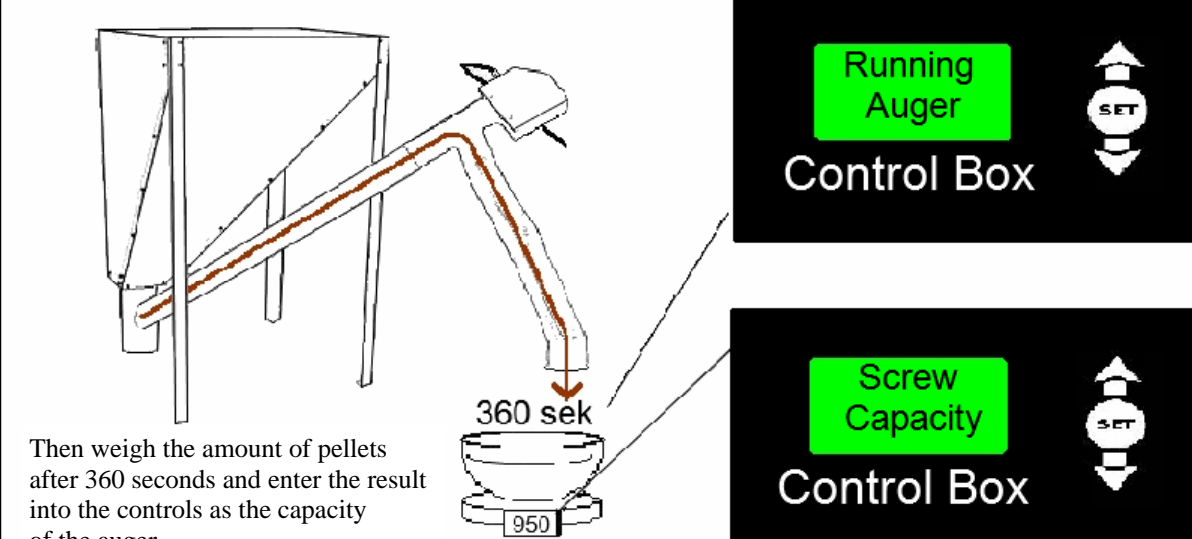

Then weigh the amount of pellets after 360 seconds and enter the result into the controls as the capacity of the auger.

Running Auger
Control Box

Screw Capacity
Control Box

360 sek
950 GRAM

Diagram description: The same pellet system schematic. The control box now shows 'Screw Capacity' in green. A timer is set to 360 seconds. Below the auger, a scale shows 950 GRAM. A red arrow points from the control box to the burner area.

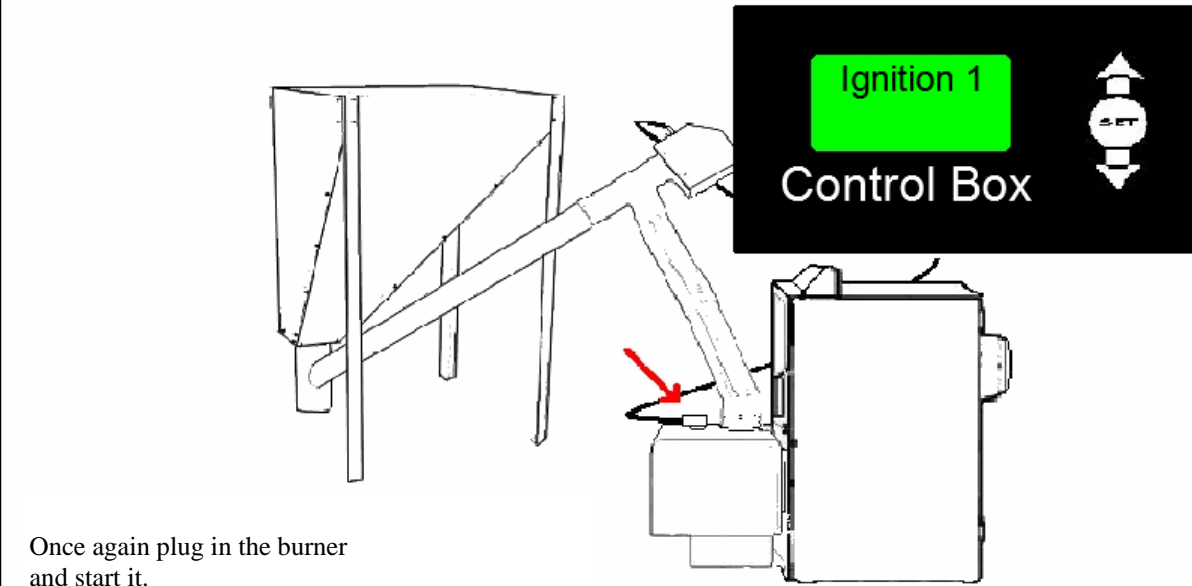

Once again plug in the burner and start it.

Ignition 1
Control Box

Diagram description: The same pellet system schematic. The control box now shows 'Ignition 1' in green. A red arrow points from the control box to the burner area.

Manual

NBE pellet system
USER GUIDE

Current operation		Various sensor readings	
Power 10 %			
Boiler Temperature	62,0 c	Boiler temperature	
62,0 c	112 c	Smoke temperature (special apparatus)	
	34 c	Temperature of mechanical stoker	
	3,2 kw	Current performance	
	12,2 %	Oxygen % (special apparatus)	
	82 lx	Current light in combustion head	

Press **SET** and the display will show SETUP for standard settings.

The **UP** button is used to increase the setting and for force-running the auger (hold for longer than 5 seconds).

The **DOWN** button is used to decrease the setting and switch the controls on/off (hold for 10 seconds).

Temperature

Auto combustion

Feed

Clock controls

Cleaning / power

Oxygen regulation

BOILER TEMPERATURE

Setting the required boiler temperature.

The burner sets the performance higher or lower depending on the figure entered (set point).

At 10 degrees over this figure the burner will begin to pause or turn itself off.

PAUSE DIFF.

The setting defining how far the boiler temperature must drop below the desired value before the burner restarts.

Temperature

Auto combustion

Feed

Clock controls

Cleaning / power

Oxygen regulation

AUGER PERFORMANCE

After setting the auger performance in 360 seconds the control will automatically calculate the amount of pellets in low steam and high steam, pellets in pause, and pellets for ignition

Under normal conditions these numbers will be correct.

To increase combustion, set the value **DOWN**.

To reduce combustion, set the value **UP**.

CHIMNEY DRAUGHT

With a strong chimney draught the ventilator performance will be higher, At low steam and during pause.

If the amount of chimney draught is increased,

the automatic calculation sets more pellets in low steam and during pause.

The smaller the chimney draught and the greater the back pressure of the boiler, the lower the value must be.

The greater the chimney draught and the lower the back pressure of the boiler, the higher the value must be.

YES/NO

Switching automatic calculations on/off.

If automatic calculation is on, only the auger performance can be set.

Manual

NBE pellet system
USER GUIDE

<p>Temperature Auto combustion <i>Feed</i> Clock controls Cleaning / power Oxygen regulation</p>	<p>LOW PERFORMANCE Setting the amount of pellets for low performance. Should be set so there is a flame when running 10% power.</p> <p>FULL PERFORMANCE Setting the amount of pellets for full performance. Should be set so that combustion is powerful when running at 100% power.</p> <p>PAUSE Setting the amount of pellets for during lag.</p> <p>If in doubts about the settings, use the automatic calculation program.</p>
<p>Temperature Auto combustion Feed <i>Clock controls</i> Cleaning / power Oxygen regulation</p>	<p>ACTIVATION / 24 HOURS Setting daily operating cycles. Switches the pellet burner on and off at set periods. 1 is one start each 24 hour. 6 is one start each 4 hour. If this function is activated, the operating cycle is turned on.</p> <p>LENGTH OF CYCLE Setting the running times using the clock. The time should be set sufficiently in advance to allow the burner to reach normal operating temperature at the set time.</p> <p>NEXT TURN-ON Switches on after a certain length of time; this is used when the boiler needs to be turned on without anyone actually being present, e.g. at 4.00 in the morning.</p> <p>CLOCK The clock depends on the feed from the power station. You can set it so it is the same as your feed. The clock is calibrated when you set it, and should match after 1-4 settings.</p> <p>WARNING The clock does not contain a battery and will lose its settings if there is a power cut. Therefore always switch off using the ON/OFF button on the regulator.</p>
<p>Temperature Auto combustion Feed Clock controls <i>Cleaning / power</i> Oxygen regulation</p>	<p>CLEANING INTERVAL Sets how often the burner should be cleaned. If you often heat on low load, the interval can be reduced to 5 minutes, with 5 seconds of cleaning.</p> <p>CLEANING TIME Set the cleaning time. The shorter the intervals the shorter the time should be.</p> <p>MINIMUM PERFORMANCE Setting minimum performance. If the pellet burner always works on low load and is having some difficulties, the minimum performance can be increased so the burner occasionally turns off.</p> <p>MAXIMUM PERFORMANCE Setting maximum performance. If the pellet burner rapidly reaches a high temperature, the maximum performance should be reduced.</p>

Manual

NBE Pellets Systems Betjenings vejledning.

**ONLY TO BE ADJUSTED
IF THERE IS A LAMBDA CONTROL MOUNTED ON THE BOILER. !!**

LOW OXYGEN

The amount of excess oxygen in the smoke at low performance.
Sets the amount of fuel so that the excess oxygen is at the required amount.
If the pellet burner smokes at low performance, set a higher percentage of oxygen.
If the photo sensor has problems recognizing the ignition, this could be caused by the ignition being too weak; set a higher value to increase the feed.
The flame should be yellowish.

FULL OXYGEN

The amount of excess oxygen in the smoke at full performance.
Sets the amount of fuel so that the excess oxygen is at the required amount.
If the pellet burner smokes at full performance, set a higher percentage of oxygen.
If the flame is angry and sputtering, set a lower percentage of oxygen.

NO/SHOW/YES

Turns oxygen regulation on/off.
Oxygen regulation set to ON –
The burner sets the amount of pellets to suit the required percentage of oxygen.
Oxygen regulation set to SHOW –
You can read the percentage, but the burner does not set the amount of pellets.

The tighter the boiler, the more you get from oxygen regulation.
It is recommended to fit the chimney with a draught stabilizer,
this will reduce the draught and cut the amount of air flowing back into the boiler.

EXTENDED SETUP (Press the SET button for 6 seconds.)

Temperature
Auto combustion
Feed
Clock controls
Cleaning / power
Oxygen regulation

Ignition
Pause
Oxygen
Correction
PID regulation
Heat alarm

Ignition
Pause
Oxygen
Correction
PID regulation
Heat alarm

FUEL

Setting the amount of pellets for ignition.

TIME

Setting maximum ignition duration.

PERFORMANCE

Setting performance of electrical ignition.

LIGHT

Setting amount of light required to interrupt ignition.

MAXIMUM TIME

Maximum pause time,
burner will then ignite electrically.

AIR

Ventilator speed during pause.

Manual

NBE Pellets Systems Betjenings vejledning.

<p>Ignition Pause Oxygen Correction PID regulation Heat alarm</p>	<p>BOOST Sets how much oxygen regulation should regulate when activated.</p> <p>CALIBRATION Calibration of oxygen sensor to ensure it gives accurate readings. Hold the exhaust gas oxygen sensor in the air and calibrate it to give it a reference value to the air (21% oxygen). WARNING! The oxygen sensor must be warm!</p>
<p>Ignition Pause Oxygen Correction PID regulation Heat alarm</p>	<p>LOW PERFORMANCE Corrects the calculation program at low feed, used in special conditions causing a difference in calculations.</p> <p>FULL PERFORMANCE Corrects the calculation program at full feed, used in special conditions causing a difference in calculations.</p>
<p>Ignition Pause Oxygen Correction PID regulation Heat alarm</p>	<p>P - REGULATION Shifts performance in relation to deviation from required temperature.</p> <p>I - REGULATION Shifts performance in relation to the time the pellet burner deviated from the required temperature.</p> <p>D - REGULATION Shifts performance in relation to the temperature trend of the boiler.</p>
<p>Ignition Pause Oxygen Correction PID regulation Heat alarm</p>	<p>MAXIMUM SHAFT TEMPERATURE Indicates the maximum temperature the burner can reach; protects against back combustion.</p> <p>MAXIMUM DIFFERENCE Indicates the maximum deviation from the set point temperature of the boiler before the burner triggers the alarm to signal a temperature drop caused by an error, etc.</p>

Manual

NBE pellet system
EXTENDED SET-UP GUIDE

SETTING THE CONTROLS

The controls work in zero-degree modulation and change these degrees automatically.



If you use an automatic calculation program after measuring the performance of the auger, no further setting should be necessary.

Setting pellets at low and full load...

During normal everyday use it is recommended to occasionally check the combustion and assess the flames. Whenever the heating pellets are changed (size or length of pellets, etc. ...), the dosing rate of the auger will also change, which will affect combustion. (However, if the burner is equipped with oxygen regulation, the burner will regulate this automatically.)

If there is a big flame on low load (10-30% performance)

(Dark, or black tips) or the ash is black.
In this case fewer pellets are required at low load.
(Reduce the chimney draught or reduce the low feed)

If there is a big flame on full load (70-100% performance)

(Dark, or black tips) or the ash is black.
In this case fewer pellets are required at full load.
(Increase the performance of the auger or reduce the full feed.)

If there is a weak flame on low load (10-30% performance)

(Small flame and sputtering stars) or the ash is light grey.
In this case more pellets are required.
(Increase the chimney draught or set the low feed higher).

If there is a weak flame on full load (70-100%)

(Small flame and sputtering stars) or the ash is light grey, with dark pellets.
In this case more pellets are required.
(Reduce the performance of the auger or set the full feed higher.)



**The pellet burner must not smoke, but must be sealed tight.
(Take care that smoke does not mingle with condensed steam.)**

**Correct combustion normally results in dark grey ash,
although this can vary slightly depending on the type of pellets used.
White and light ash in the boiler means excess air.**

Having the boiler set up correctly has a great effect on the economy of burning wooden pellets

Fuel type

The boiler is set up for wooden pellets Ø 5-8mm,
which do not burn to cinders!! (Hard ashes)

Manual

NBE pellet system
CLEANING GUIDE

When cleaning, turn off the burner...

Turn off the controls (hold the on/off button down for 10 seconds) and let the burner cool down for about 3 minutes, when it is completely switched off the burner is ready to be cleaned. Unplug the burner, remove the cover and the drop shaft, and unscrew the burner from the boiler before continuing.



The burner should be cleaned regularly and whenever necessary. This will ensure that the burner runs as economically as possible. The more suitable the boiler you have and the better the pellets you use, the longer the intervals between each cleaning session.

The boiler...

Clean the ash out of the boiler and brush off all the surfaces to remove any deposits. Be very careful of the ash in the backflow valve and the chimney pipe. The chimney-sweep DOES NOT CLEAN the chimney pipe, you must do this yourself ... An old vacuum cleaner or ash bucket are especially suitable, as the ash does not normally contain carbon particles or tar.

Area for Cleaning

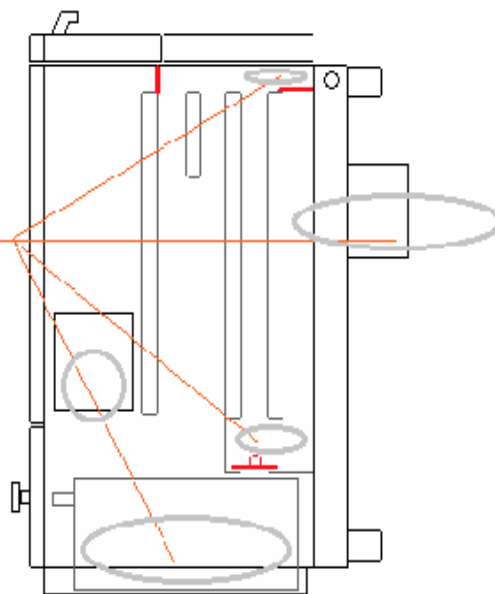

Combustion heads...

Remove the ash and any cinders from the grate. Remove any remnants of pellets from underneath the grate. Wipe the flame indicator. Ensure there is nothing in the ventilator.



**VERY IMPORTANT!!!
THE COMBUSTION HEAD WILL
BE DAMAGED IF THE GRATE IS
NOT POSITIONED CORRECTLY!!!**

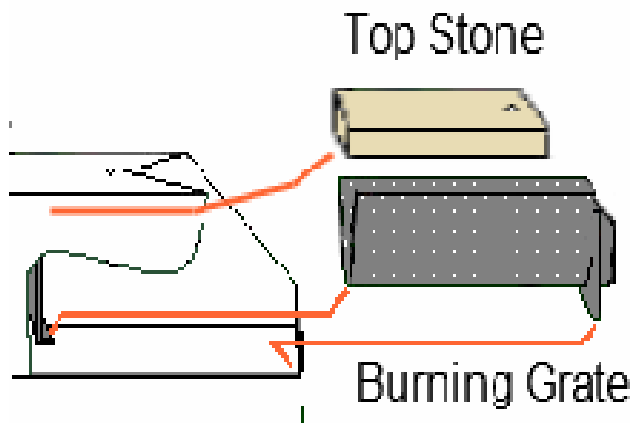

Pellet hopper...

As the pellets you put in the hopper contain detritus, the hopper should be completely emptied from time to time. The more detritus there is in the hopper, the less the auger doses, which can interfere with the settings cause the burner to cut out. The frequency with which you empty the pellet hopper depends entirely on the shape of the hopper and the quality of the fuel you use.

Restarting after cleaning...

Reassemble the pellet burner and ignite it (hold the on/off button down for 10 seconds), at which point the burner will start automatically. DO NOT FORGET to replace the cover, to ensure that the temperature of the combustion chamber is measured correctly.

Manual

NBE pellet system
TROUBLESHOOTING

Problem	Cause	Solution
ALARM HOT DROP SHAFT OR BACK SMOKE	<ol style="list-style-type: none"> 1. Cinders/ash in the combustion head. 2. Ash in the boiler, smoke pipe and chimney. 3. Backflow valve installed incorrectly in the boiler. 4. No draught in chimney. 5. Performance too high (kW) in proportion to boiler. 6. Defective sensor. 7. Air flow wrong. 	<p>Clean the combustion chamber! Clean the boiler, smoke pipe and chimney! Rectify or remove the backflow valve panel in the boiler! Strip the insulation in the smoke pipe, raise the chimney! Contact your dealer! Change the heat sensor on the printed circuit board! Contact chimney-sweep or NBE!</p>
ALARM FAULTY IGNITION	<ol style="list-style-type: none"> 1. Combustion grate not fitted correctly. 2. Ash/cinders in the combustion head. 3. Damp pellets. 4. Ignition not fitted correctly. 5. Defective ignition. 6. Excessive chimney draught. 7. Photo sensor is faulty/covered in soot. 8. Blocked ventilator. 	<p>Quadrangular holes from combustion chamber. Clean the combustion chamber! Change supplier/storage! Fit into quadrangular holder. Change ignition/ignite manually! Install a draught stabilizer in the chimney. Clean/change the sensor. Clean the ventilator and check that it works.</p>
ALARM LOW BOILER TEMPERATURE	Boiler temperature has not exceeded 35 degrees after 2 hours of operation, or has dropped below 35 degrees when running.	<p>Low combustion chamber performance. Check pellet feed/ventilator! Check that the head sensor is on the boiler.</p>
ALARM PLUG NOT FITTED	<ol style="list-style-type: none"> 1. Plug on the burner is not fitted correctly. 2. Dirt in the safety bolt. 3. Faulty sensor. 	<p>Check the plug on the burner ! Clean any pellet residue from the plug. Change the sensors (photo/temperature).</p>
Control display is black	<ol style="list-style-type: none"> 1. Boiler overheated 2. Control fuses broken. 3. Contrast button not set on controls. 	<p>Reset overheating fuse! Change the fuses. Check for short circuits! Set contrast button.</p>
Burner ejects HFI relay	<ol style="list-style-type: none"> 1. Ignition faulty. 2. Faulty cables. 	<p>Change Ignition/ignite manually! Check cables and plug on the burner. Check condition of burner.</p>
Burner goes out on "LOW STEAM" Weak flame	<ol style="list-style-type: none"> 1. Fuel supply instable. 2. Pellets remain in pipe. 3. Low feed is set too low. 4. Chimney draught estimated wrongly. 5. Amount in auger measured incorrectly. 	<p>Check there is no sawdust at the entrance to the auger. Check the slope of the auger. Check that the auger drops into the combustion chamber. Increase chimney draught and watch LX indicator at low performance. Measure the auger again for 360 seconds.</p>
Burner goes out on "PAUSE" Weak flame	<ol style="list-style-type: none"> 1. Fuel supply instable. 2. Pellets remain in pipe. 3. Chimney draught is set too low. 4. Chimney draught too strong. 	<p>Check there is no sawdust at the entrance to the auger. Check the slope of the auger. Check that the auger drops into the combustion chamber. Watch LX indicator during pause. Increase chimney draught. Install a draught stabilizer in the chimney.</p>
Excessive pellet consumption / boiler will not reach required tem- perature	<ol style="list-style-type: none"> 1. Combustion set incorrectly. 2. Chimney draught too strong. 3. Backflow valve installed incorrectly in the boiler. 4. Bad boiler /low efficiency/ insulation. 5. Combustion chamber working too hard. 6. Damp pellets/poor quality. 	<p>Check that the ash is dark grey! Measure the chimney draught / install a draught stabilizer. Check boiler, install backflow valve. Measure smoke temperature, then strip boiler insulation! Reduce performance of combustion chamber. Use efficient fuel.</p>
Boiler and burner are clogged up / black.	<ol style="list-style-type: none"> 1. Too many pellets. 2. Lag set incorrectly. 3. Blocked ventilator. 	<p>Increase auger performance in calculation program. Reduce chimney draught. Clean the ventilator!</p>

Manual

NBE Pellets Systems ELECTRICAL WIRING DIAGRAMS

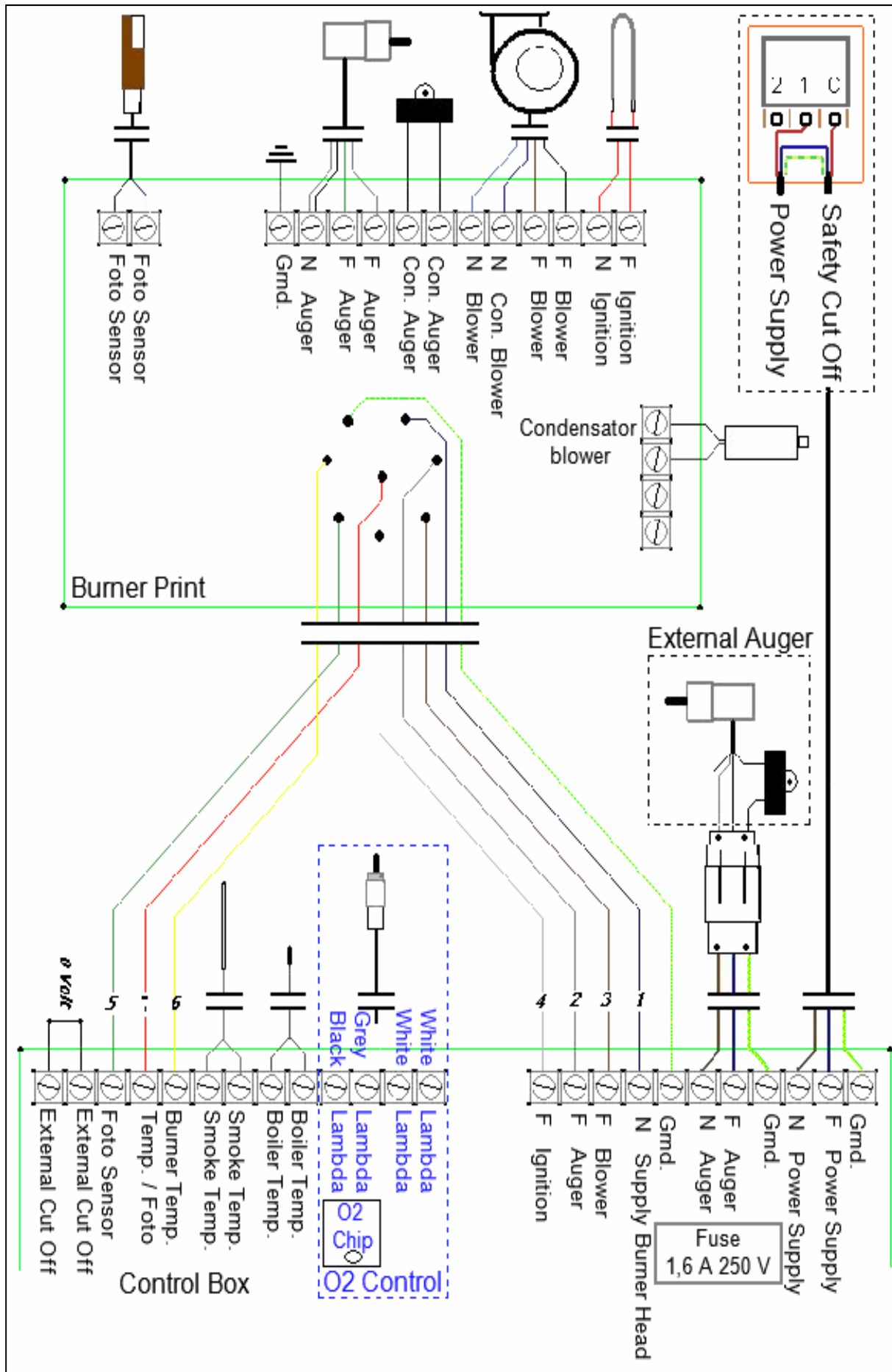

Manual

NBE Pellets Systems

WARANTY

All products purchased from NBE are naturally covered by the applicable Danish purchasing law. Products come with a two-year warranty valid from the date of receipt.

However, this does not cover the exhaust gas oxygen sensor, electrical ignition or the combustion grate. These are considered to be replaceable parts.

The warranty only covers production and material faults.

If there is a fault with goods under warranty,

NBE will send a replacement part for repair at no cost to the purchaser.

The purchaser shall install the replacement part himself.

If NBE offers to repair a defective part, the purchaser shall send it to NBE, who will repair it and then return it.

The warranty becomes void if the fault is caused through circumstances caused by the purchaser, by accident, or by improper use of the goods, incorrect cleaning, chimney condition, as well as circumstances unrelated to NBE. In addition to this the warranty becomes void upon improper use of the boiler, for example by using fuel not approved by NBE. The warranty does not cover parts such as the exhaust gas oxygen sensor, electrical ignition and combustion grate. The purchaser is obliged to check the goods immediately upon receipt. If on the basis of this inspection the purchaser would like to make a claim with the effect that the delivery was inadequate or somehow at fault, the customer must immediately file the claim with NBE without delay. Goods can only be returned upon agreement with NBE. To the extent that NBE is liable to the purchaser, the responsibility of NBE is limited to direct damage, i.e. damage to connected equipment, and indirect damage, for loss of earnings, operating losses, connection costs, etc.

responsibility:

NBE accepts no responsibility as a result of the purchaser's legal relations with third parties.

All orders are accepted with the exception of *force majeure*, such as war, civil unrest, natural catastrophes, strikes and lockouts, breakdown in the supply of raw materials, fire, damage to NBE or its supplier network, breakdown in transport facilities, bans on import or export or any other event which prevents or restricts NBE from supplying its goods.

In the case of *force majeure*, NBE may choose to either cease trading in full or in part, or to supply the contractual goods as soon as the obstacle preventing normal delivery has passed. In the event of *force majeure*, NBE is in no way responsible for any damage caused to the supplier as a result of its failure to deliver.

We do not vouch for printing errors, price adjustments, changes in the exchange rate, sold-out goods or changes to specifications in products such as the manual.

It is the purchaser's responsibility to have the equipment registered with the appropriate offices; any disputes between the authorities and the purchaser do not relate to NBE and are not its responsibility.

Upon request the following documents can be issued:

12. Exception to pressure expansion from Work Supervisor.

13. Declaration of conformity.

14. DTI type approval (Danish Technological Institute).

15. Printed circuit board diagrams.

This material is also available at www.nordjysk-bioenergi.dk.

Manual

NBE Pellets Systems

INSTALLATION OF OXYGEN EQUIPMENT

Installation of oxygen equipment

Install the exhaust gas oxygen sensor into the boiler (Diag.1) and ensure it will be in good contact with the flue gases, e.g. into the smoke outtake or the front doors.

It is important that the installation is airtight.

Attention – it must be possible to remove it.

Then disconnect the power and remove the doors.

Fit the exhaust gas oxygen sensor cable to the four terminals (marked with blue, Diag.2).

The color is on the printed circuit board.

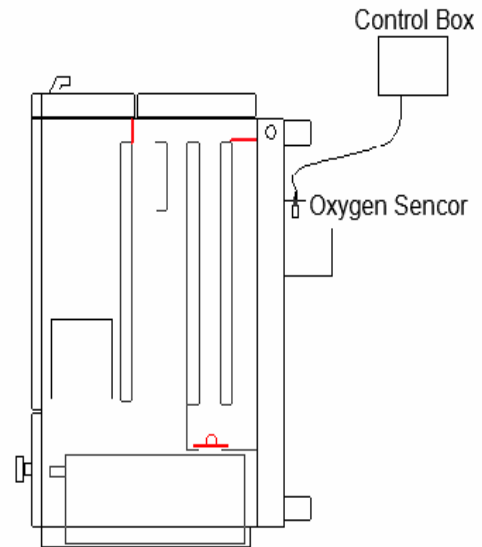

Diag.1 (Controls, exhaust gas oxygen sensor).

Install the enclosed chip (marked as a black square, Diag.2).

The little dot at the top of the chip must point in the same direction as the markings on the printed circuit board holder.

(facing away from the screw terminals).



**THE CHIP MUST NOT BE TURNED THE WRONG WAY
THIS WILL DAMAGE IT!!!**

Fit The doors back on.

Connect the power to the controls and wait about 15 minutes for the exhaust gas oxygen sensor to warm up. You can now calibrate it. Find the oxygen regulation in the menu and select SHOW. Switch to the extended menu and calibrate the oxygen and the sensor.

Note: the exhaust gas oxygen sensor must be held in the air.

The burner will continue without having regulated the oxygen, but the percentage of oxygen will appear on the display. Fit the exhaust gas oxygen sensor back into the boiler and spend a little time detecting the percentage of oxygen at LOW LOAD and FULL LOAD, which is when your burner fires at its best.

There should be a powerful flame at FULL LOAD (100%) and a slightly weaker one at LOW LOAD (10%).

Note that the tighter the boiler is and the smoother the chimney draught, the more accurate the oxygen percentage measurements will be.

It is always recommended to install a draught stabilizer into the chimney together with oxygen regulation.

When you have found the optimum percentage of oxygen, go into the menu below oxygen regulation and select YES, then enter the percentage of oxygen detected into LOW OXYGEN and FULL OXYGEN.

The controls will then automatically set the auger times into LOW FEED and FULL FEED.

If you want more powerful combustion, set a lower percentage of oxygen.

If you want weaker combustion, set a higher percentage of oxygen.

Diag. 2

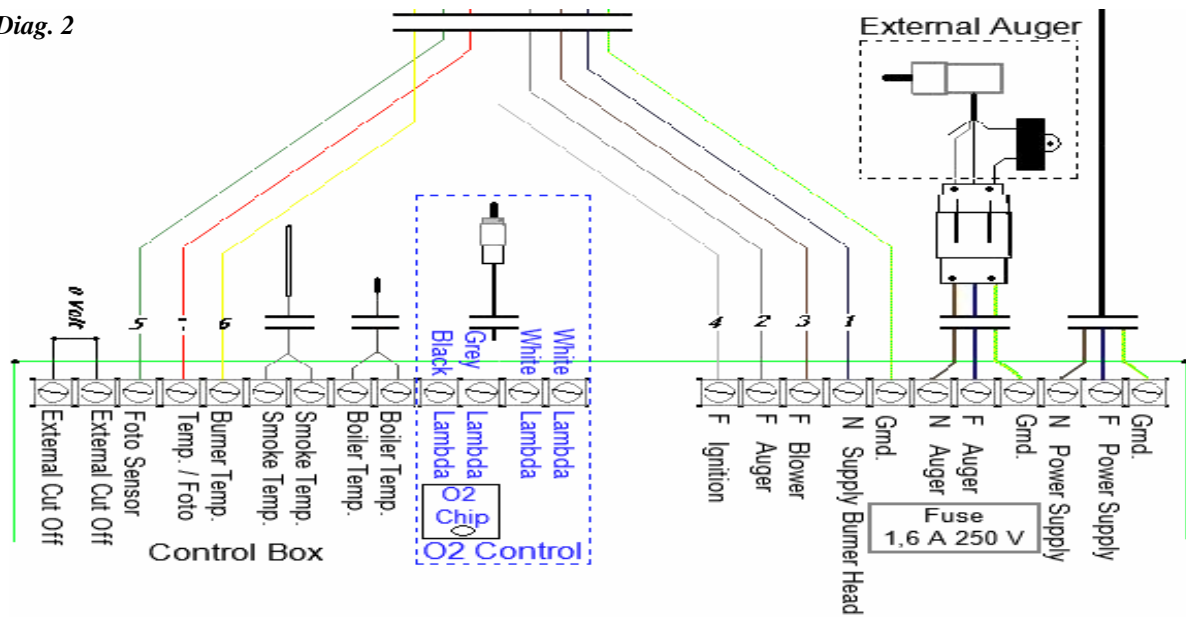

Manual

NBE Pellets Systems MOUNTING THE PELLET HOPPER

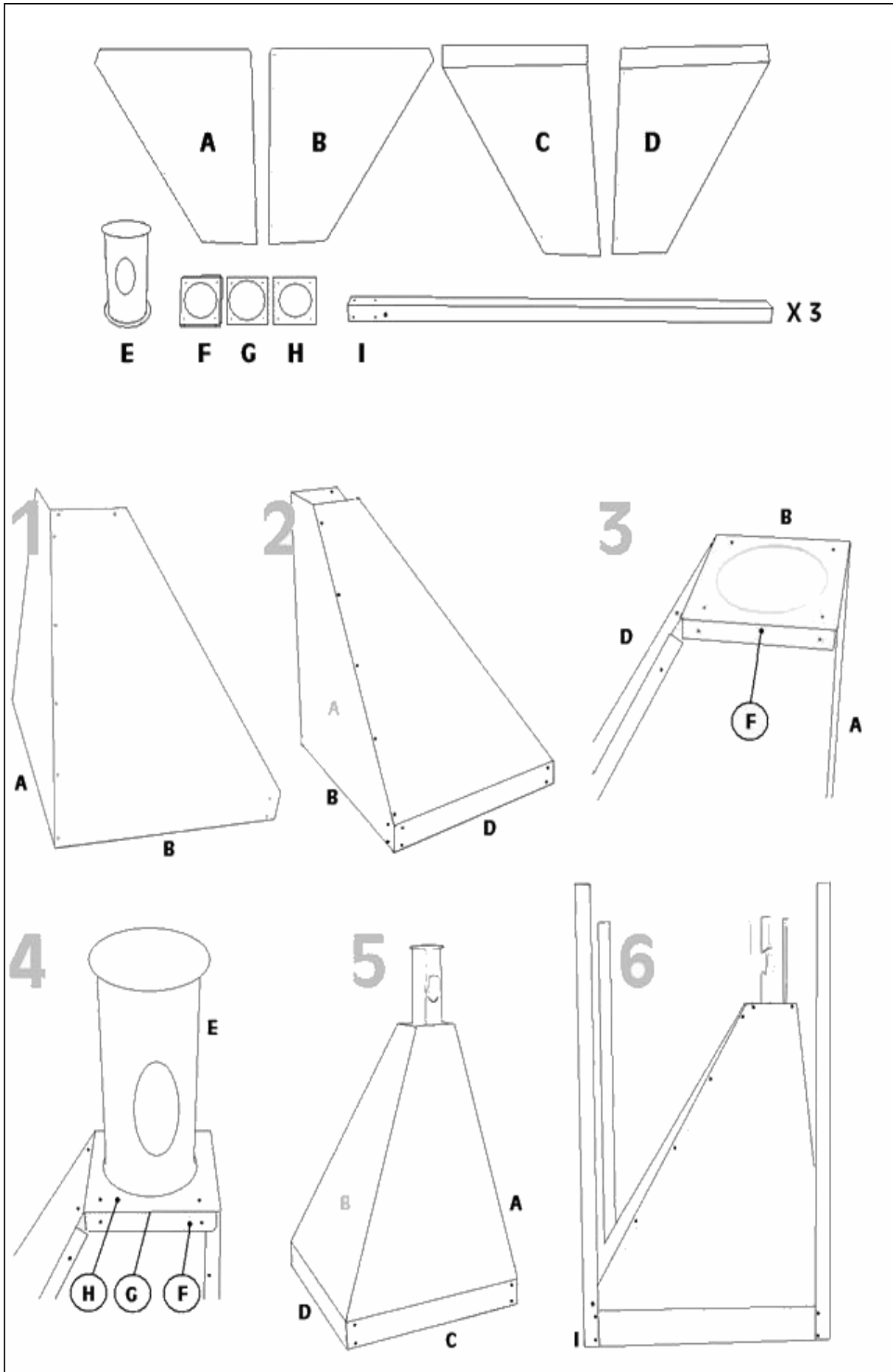

Manual

NBE Pellets Systems

EXCEPTION FOR PRESSURE EXPANSION

NBE
Jannich Hansen
Brinken 10
DK 9830 Oester Vraa

Landskronegade 33
2100 Copenhagen
Telephone 39152000
www.arbejdstilsynet.dk
Your contact JH
Our ref. 20030027413
Our contact.
G.Agersnap
Direct telephone
0045-3915265915

Re: Use of burner to burn wooden pellets type Woody, Scotte, Bio-comfort and Boink in boiler equipment in relation to smaller, closed facilities in compliance with Work Supervisor Regulations for Hot-water Heating Systems. (publ. 42/1980 para 4)

With regard to your query of 1 September 2006 concerning the use of the burner to burn wooden pellets type Woody, Scotte, Bio-comfort and Boink in boiler equipment in relation to smaller, closed facilities with pressure expansion, we can report that the Work Supervisor has perused the submitted materials and can declare that the burner for wooden pellets type Woody, Scotte, Bio-comfort and Boink can be installed in the heat facilities listed in paragraph 4 of the Work Supervisor publication no. 42/1980, Regulations for Hot-water Heating Systems.

It is assumed that the boiler contains the requisite amount of water and that the entire heating facility is designed in exact compliance with the instructions given in publication 42/1980, and also that the electricity supply will only be connected to a boiler with a fitted and connected thermostat with the appropriate overheating safety fuse which must be manually reconnected after activation.

All heating in the boiler must take place by means of the pellet combustion chamber, and only fuels listed in the instructions may be used. Otherwise the equipment must be installed with an open expansion (compare paragraph 2 in publication 42/1980).

This decision is based on the enclosed instructions and diagrams, Test Report no. 300-ELAB-0741, as well as the Power Dropout Test with readings recording the build-up of heat in the boiler if the power supply to the equipment is interrupted.

Best regards,

G.Agersnap